



LS25/50 LASERSCORE®

ISSF approval phase 1, 2 and 3

**Basic configuration of the target
for 25 resp. 50 meters
rifle and pistol**

**Installation overview
and components**

SIUS AG

Im Langhag 1 | CH-8307 Effretikon | Switzerland

Phone +41 52 354 60 60

www.sius.com | info@sius.com



Standard configuration

Target LS25/50
with basic equipment SA951.

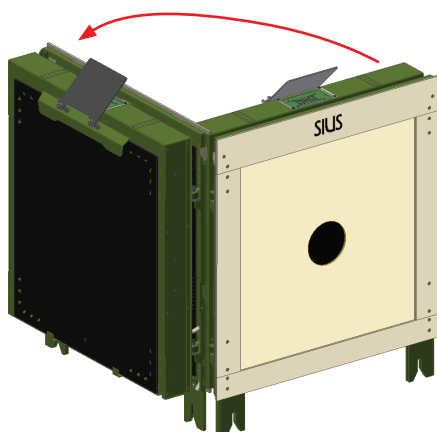

By default, the target will be opened on the rear side to the left.

If it is necessary, that the target opens to the right, the screws in the rubber pads can be changed. In this case it is necessary to use a longer STYX connecting cable.

Installation overview STYX/LON hybrid network for 1–10 lanes

The installation is divided into 4 groups: group target line (A), group firing line (B), group segment control (C) and group control room (D). In addition, country-specific power supply cables are needed. For all 25m disciplines the targets are already equipped with red/green light signals.

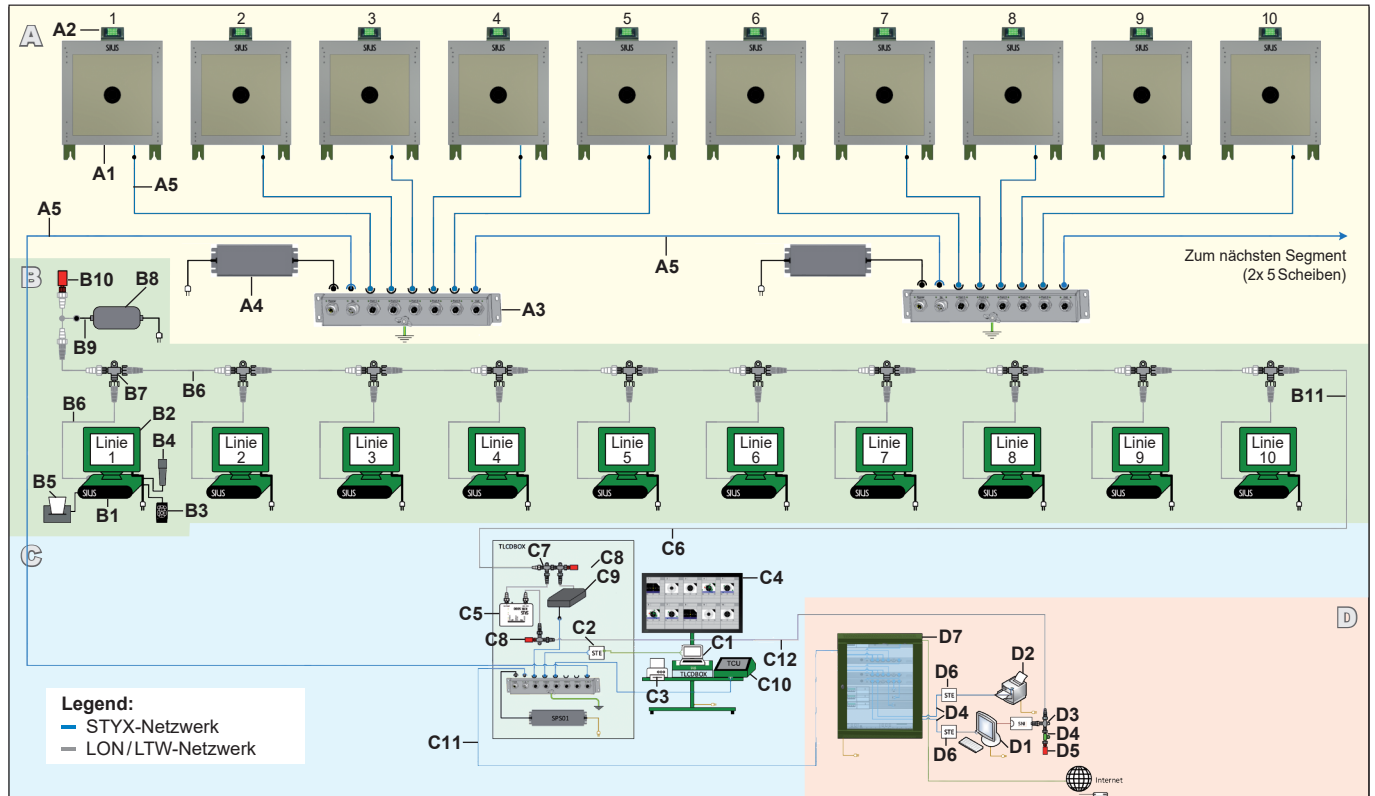

Pos.	Article no.	Description
A	Target line	
A1	LS2550	Target 25m resp. 50m
A2	LS2550AN002	Display mirror for light signal, dibond 3mm (option)
A3	SNC01	STYX network connector (for max. 5 targets)
A4	SPS01	Power supply for STYX-Network-Connector
A5	KSN001-L*	Cable STYX (L*=length)
B	Schützenseitig	
B1	CU951-CLUB	Control unit, for clubs, schools etc. (ISSF approval phase 1 and 2)
	CU951-ISSF	Control unit, with software for ISSF competitions (ISSF-approval phase 1, 2 and 3)
B2	M951	Monitor TFT 10.4" (26cm) Touchscreen incl. power supply AAG233 and USB cable (connection touchscreen)
B3	RC211	Remote control (option)
B4	AAG133	Barcode scanner (option)
B5	D112-USB-N	Thermal printer incl. power supply (option)
B6	KL001-2.0	Cable LTW male-fem 2.0m
B7	KL001-T	T-Adapter fem/fem/male LTW IP67
B8	NT211V0	Power supply for 10 lines 225W with LTW 230V
B9	KL013	Y power cable for NT211
B10	KL001-R	Terminating resistor, red, male LTW IP67
B11	KL001-20.0	Cable LTW male-fem 20.0m
C	Segment control (10-Lane-Command-Desk)	
C1		Windows-PC with accurate hardware (on request or by customer)
C2	TLCD-STYX	Software 10-Lane-Command-Desk incl. Adapter STYX to Ethernet
C3		Laser printer (on request or by customer)
C4		Monitor for spectators > TV/Beamer (on request or by customer)
C5	RTR5000	RTR5000 LON-Router FTT10-FTT10, size (WxHxD): 110x25x90mm, weight: 120g (needed for installations with more than 10 lines)
C6	KL001-2.0	Cable LTW male-fem 2.0m
C7	KL001-T	T-Adapter fem/fem/male LTW IP67
C8	KL001-R	Terminating resistor, red, male LTW IP67
C9	STL01	Converter STYX to LON
C10	TCU	Time control unit for 25m
C11	KSN001-L*	Cable STYX (L*=length)
C12	KL001-L*	Kabel LTW male-fem (L*=length)
D	Control room	
D1		Windows-PC with accurate hardware (on request or by customer)
		Software SIUSDATA and SIUSRANK
D2		Laser printer (on request or by customer)
D3	KL001-T	T-Adapter fem/fem/male LTW IP67
D4	KL001-I	I-Adapter fem/fem LTW IP67
D5	KL001-R	Terminating resistor, red, male LTW IP67
D6	STE01	Adapter STYX to ethernet
D7	SR01	Rack 19", size (WxHxD): 600x505x450mm, weight: 16kg
	SNM01	STYX network master
	SNC02	STYX network connector 19" (number of needed devices depends on the size of the installation)
	SNS01	STYX network server (number of needed devices depends on the size of the installation)
	UPS001	Uninterruptible power supply
D8	KSN001-L*	Cable STYX (L*=length)
		Country-specific power supply cable > AA1**

Target LS25/50 for small bore rifle and pistol

The target LS25/50 is designed for distances of either 25m or 50m. The same targets are used for both distances. For the pistol disciplines of 25m, the target is equipped with an integrated red/green light signal.

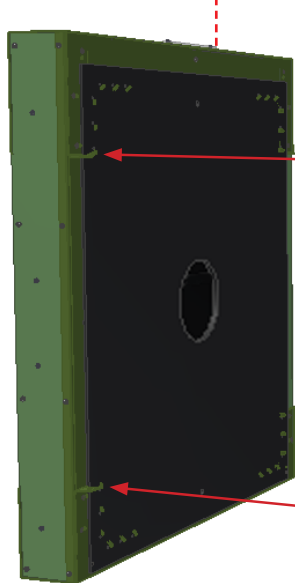
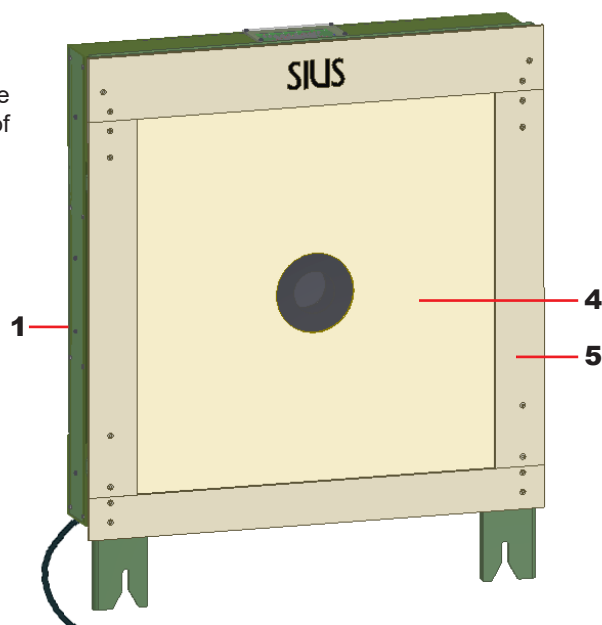
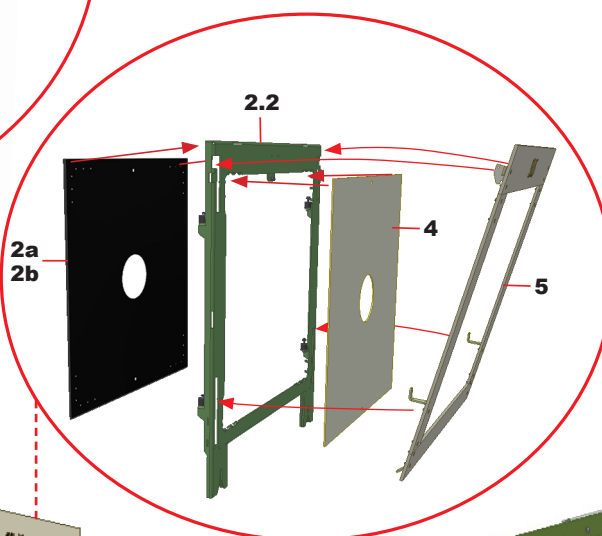
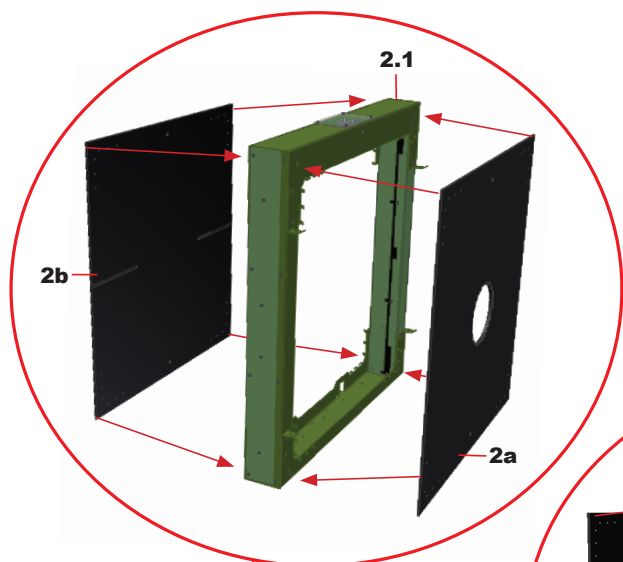

Measuring frame complete, assembled

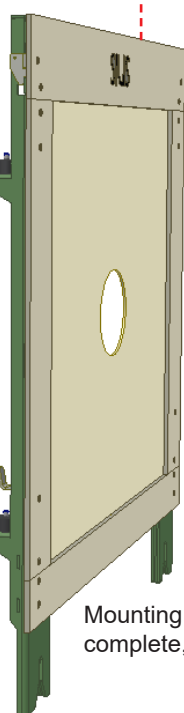

Mounting frame complete, assembled

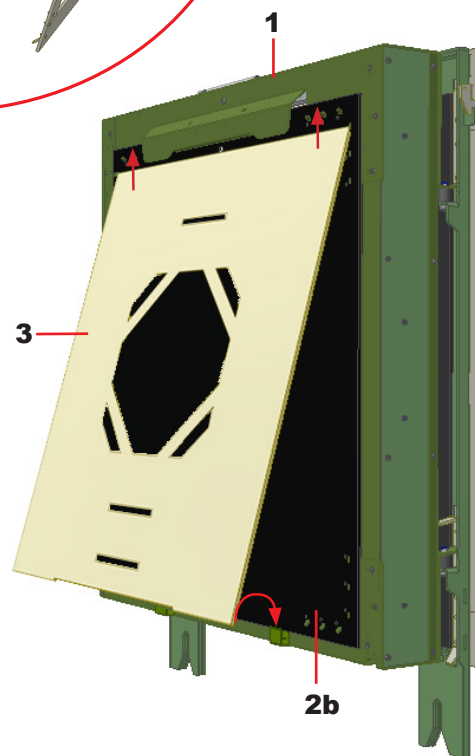

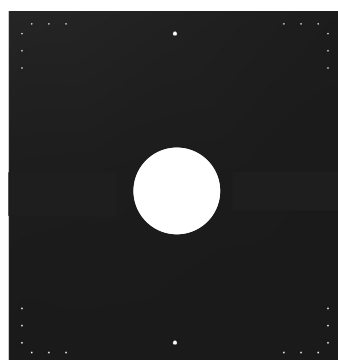

2a

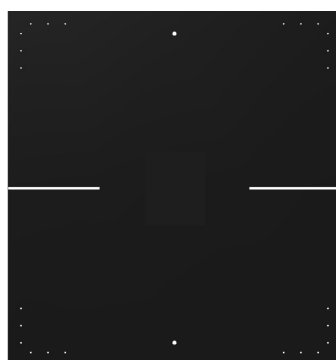

2b

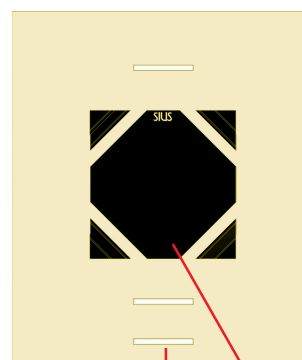

3a

3b

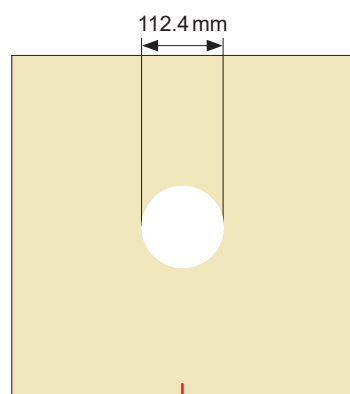
ISSF small bore rifle
target front mask 50m

4a

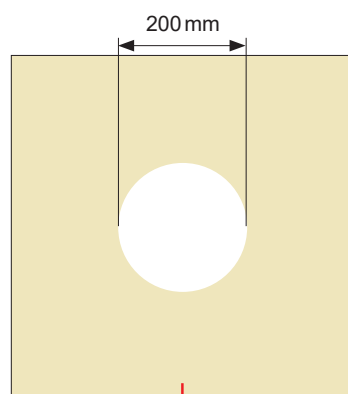
ISSF precision pistol
target front mask 25/50m

4b

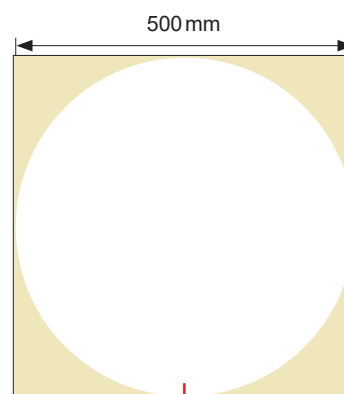
ISSF rapid fire pistol
target front mask 25m

4c

Pos.	Article no.	Description
Target LS25/50		
1	LS2550	Complete target incl. reinforced aluminum front frame for calibers 22, 32, 38 (except steel shell projectiles), incl. connection cable, length 1,4m. Size (WxHxD): 660x775x125mm, weight: 16 kg (without accessory), Consumption: 7.6W, detection surface: 520x531mm
	LS2550D007	Complete target without reinforced aluminum front frame (if using an alternative reinforced front frame)
Optional accessory and spare parts		
2.1	LS2550D003	Measuring frame, complete incl. rubber membranes 2a + 2b
	LS2550D008	Measuring frame without rubber membranes
	LS2550D009	Sensor board left
	LS2550D010	Sensor board right
2.2	LS2550D002	Mounting frame, complete incl. rubber membrane 2a
2a	LS2550A004	Rubber membrane black, for 50m small bore, with hole
2b	HS25/50A071	Rubber membrane black, for 25m rapid fire pistol, with aiming line, without hole
3a	HS25/50A055	Bracket for witness paper (option) > manual shot control
3b	AZF046/100	Witness paper for replacement, set of 100 pieces (option) > manual shot control
4a	S50A030	ISSF small bore rifle target front mask, top skin (installed), caliber 22
4b	S50A031	ISSF small bore pistol front mask (optional), caliber 22, 32 und 38
4c	S50A033	ISSF rapid fire pistol target front mask, polyethylene plate (optional), calibers 22, 32, 38
5a	LS2550D001	Reinforced front frame (aluminum) for calibers 22, 32, 38 (according to the ISSF rules, except steel shell projectiles) Color: RAL1015 light ivory (→ in case of many frame hits use 5b)
5b	LS2550AN005	Optional front frame (steel for caliber 22, 32, 38 (according to the ISSF rules, except steel shell projectiles) Color: RAL1015 light ivory

Sun and weather protection

To make sure, that no direct sunlight is falling into the detection system of the target, the cover for sun and weather protection should be installed. It must be installed, if sunlight can fall from above, from behind or from the side into the target.

In the best case, construction measures (roofing of the targets) should prevent incidence of light behind the targets (see example in installation manual for LS25/50 > B-INWA-LS25/50).

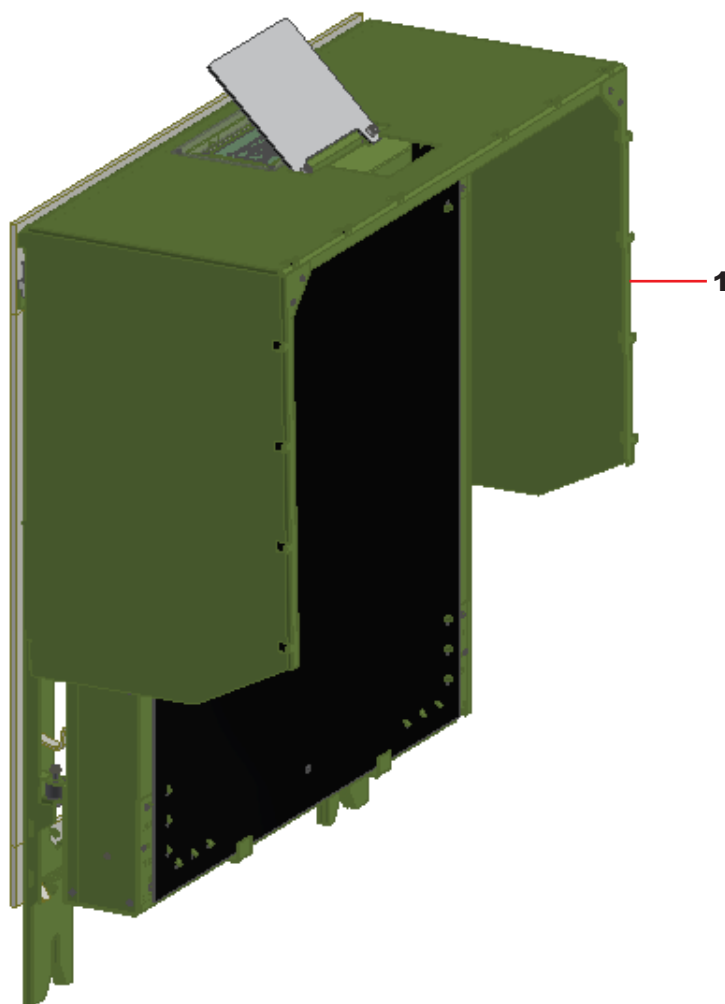

Pos.	Article no.	Description
		Sun and weather protection
1	LS2550AN004	Sun and weather protection (without display mirror for light signals shown above)

Black target centre (bull's eye)

There are several possibilities to ensure that even a heavily shot-up target centre remains visible as black for the shooter. **In the best case construction measures (roofing) should prevent incidence of light behind the targets (see example in installation manual for LS25/50 > B-INWA-LS25/50).**

The accessories below should be used if the required construction measures can't be implemented sufficiently.

Center shade provider on bullet trap/wall

If using a bullet trap it is possible to mount a phantom target with center shade provider on it. It prevents incidence of light in the centre. If there is no bullet trap, it is also possible to mount it directly to a wall.

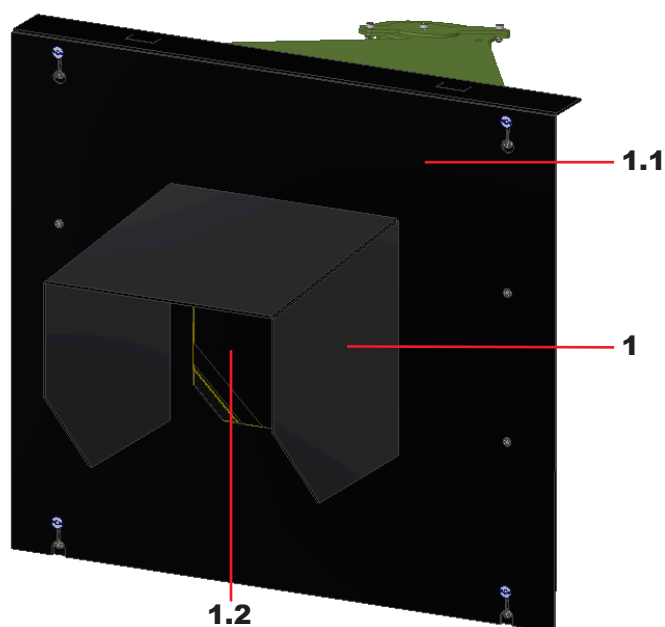

Center band mechanism

The center band mechanism is mounted on the back of the target. It moves the band forward after each shot which hits the centre.

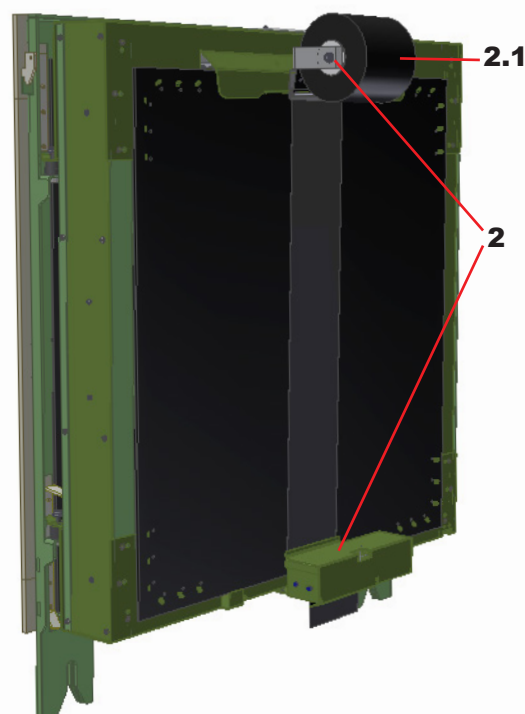

Pos.	Article no.	Description
Center shade provider on bullet trap/wall		
1	PTM2550A007	Center shade provider for phantom target (option), PP-multi-wall, size(WxHxD): 327x316x350mm
1.1	PTM2550A005	Phantom target for manual shot control and cross shot detection, PP-multi-wall, size (WxHxD): 770x690x3,5mm
Optional accessory and spare parts		
1.2	AZF046/100	Witness paper for replacement (option) > manual shot control, set of 100 pieces
Center band mechanism		
2	HS25/50AN005	Center band mechanism
Optional accessory and spare parts		
2.1	S10D008	Plastic tape roll for center band mechanism

Multi target holder for mounting on a carrier 25m/50m

The target holder SHS01 enables the installation of a LS25/50 target to the front or the back of a carrier (wall, wooden beam etc.). The target holder SHS03 enables the installation of the target to the front or the back of a wall with an opening. If the target is mounted to the front of a wall the spacers SHS03AN001 are needed additionally.

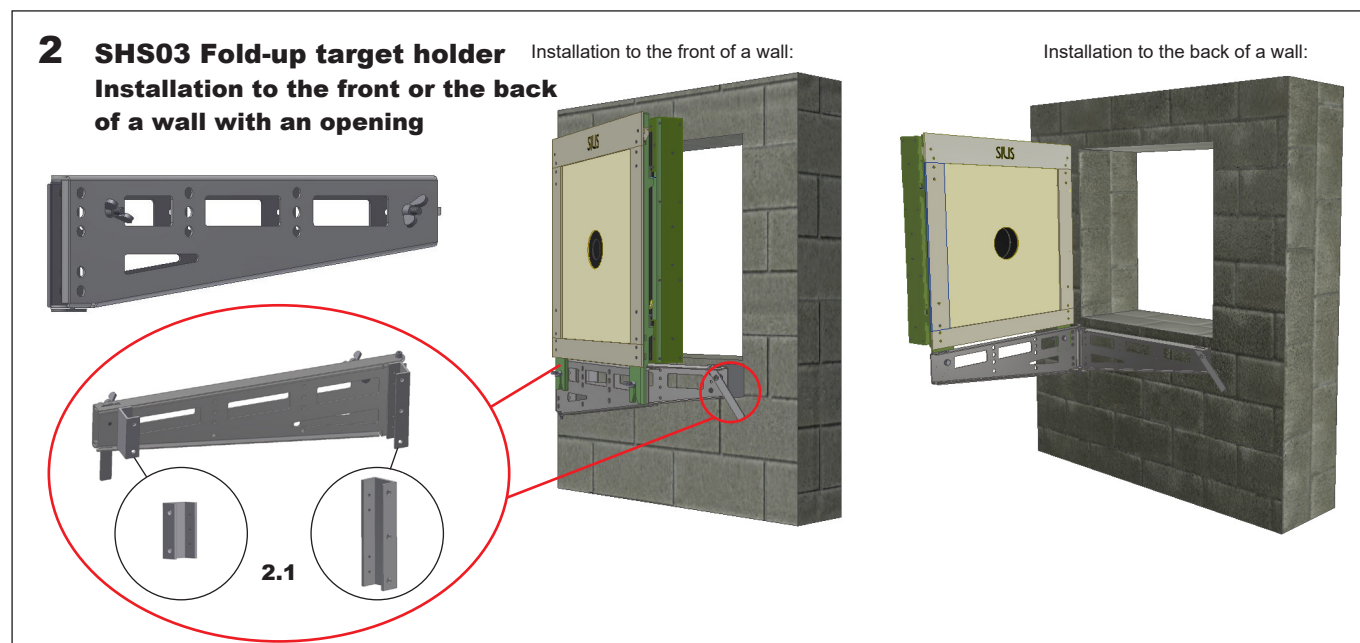
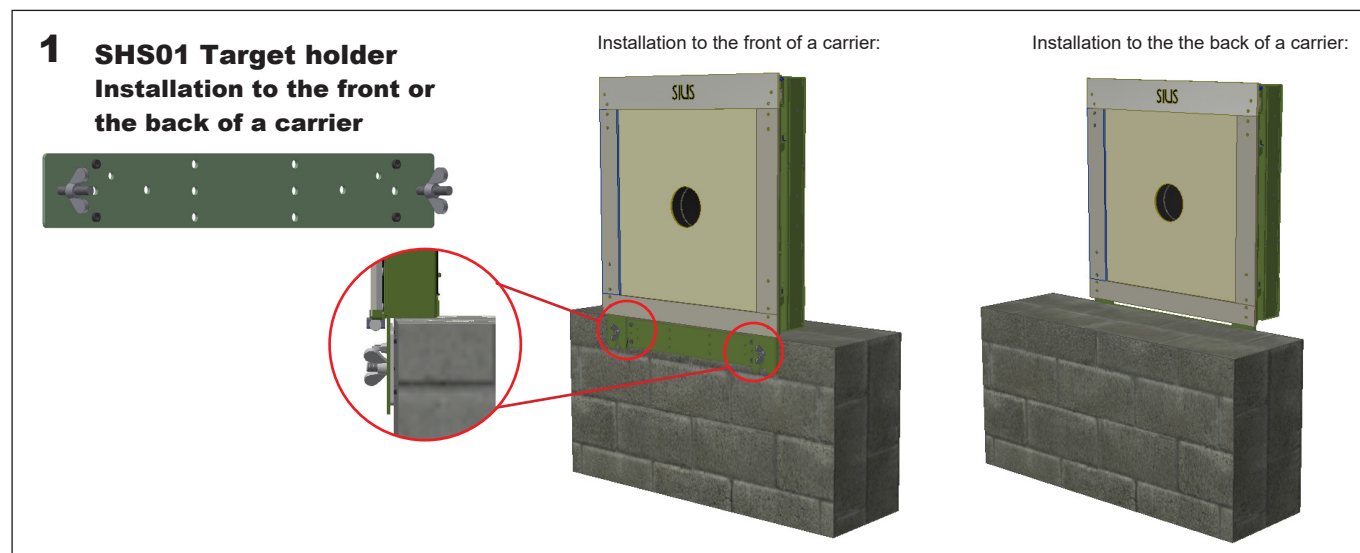

Pos.	Article no.	Description
Target holder for LS25/50		
1	SHS01V0	The target holder SHS01V0 is used for the installation to a wall, steel or wooden beam. The installation can be done to the front or the back of the carrier.
2	SHS03	The target holder SHS03 is used for an installation on a wall with an opening. The fold-up holder enables best access to the target (maintenance).
2.1	SHS03AN001	Spacers for SHS03, set with 2 pcs. The spacers are mounted on the left and the right side at the back of the target holder.

Target holders for 50m

The target holders SHS07 (without holder for bullet trap) and SHS09 (with holder for bullet trap) enables the mounting of a single LS25/50 target. The height corresponds to 50m ISSF (75cm). Both holders can be equipped with feeds, wheel casters and floor fixings according to the individual needs. A special bullet trap has been developed for small bore projectiles.

1 SHS07 Target holder (for use without bullet trap)

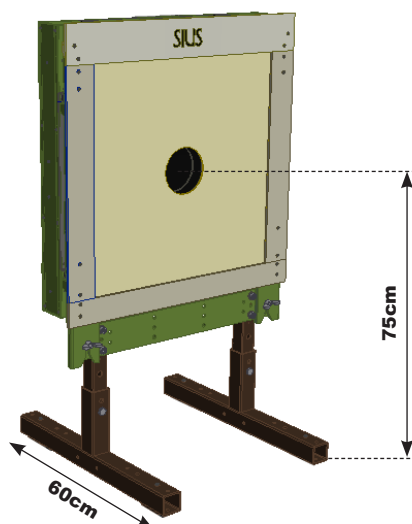

2 SHS09 Target holder (for use with bullet trap)

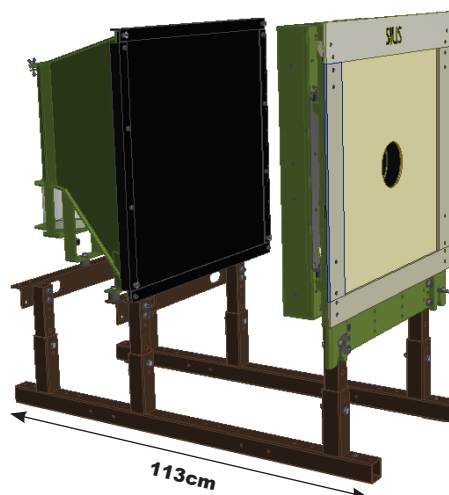

KFS2550 Bullet trap for small bore projectiles

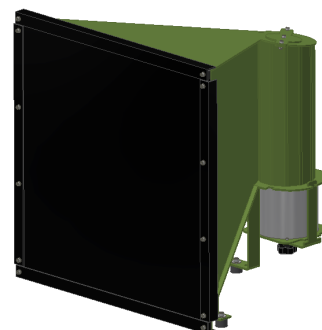

Article no.	Description
KFS2550	Bullet trap for target LS25/50 (see also page 15)

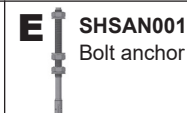
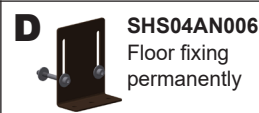
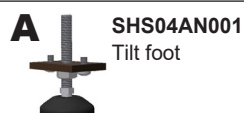

Pos.	Article no.	Description
Target holder for target LS25/50		
1	SHS07	Target holder, for use without bullet trap, excl. feet, wheel casters and floor fixings.
2	SHS09	Target holder, for use with bullet trap, excl. feet, wheel casters and floor fixings.
Optional accessory and spare parts		
A	SHS04AN001	Tilt foot for target holder, set with 4 pieces
B	SHS07AN001	Wheel caster for target holder, Ø 80mm, set with 4 pieces
C	SHS04AN005	Floor fixing temporarily for target holder, set with 2 pieces
D	SHS04AN006	Floor fixing permanently for target holder, set with 2 pieces
E	SHSAN001	Bolt anchor with washer and nuts, set with 4 pieces

Multi target holder short for 25m ISSF disciplines

The target holders SHS04V0 (without holder for bullet trap) and SHS06V0 (with holder for bullet trap) enables the mounting of LS25/50 targets. The holders can be equipped with feet, wheel casters and floor fixings according to the individual needs. The targets can be adjusted along the board. These target holders has been specially developed for rapid fire in which 5 targets are mounted and the distance from target center to target center must be 75cm. Except for rapid fire, one target must be removed for all 25m disciplines for which the ISSF regulations stipulate a distance of 100cm. To allow the simplest conversion between the various disciplines and the constant use of 5 targets, we particularly recommend the use of the multi target holder SHS04V1 resp. SHS06V1 (see page 11).

1 SHS04V0 Multi target holder (setup width 380cm, for use without bullet trap)

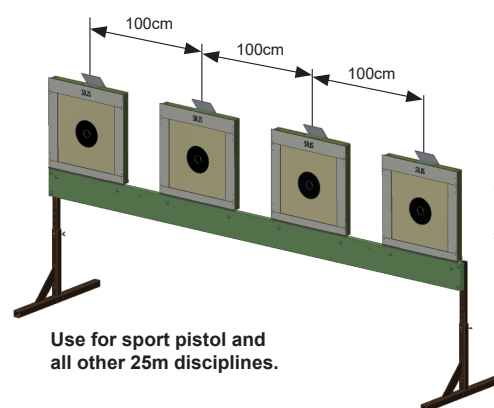
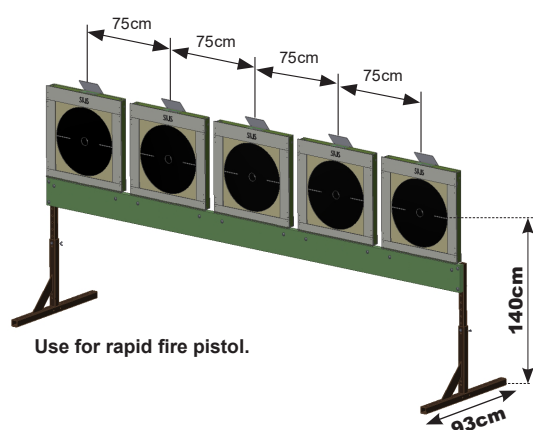

Only 4 lanes can be used with the short holder SHS04V0.

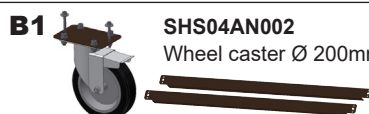
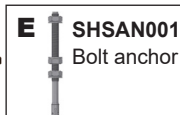

2 SHS06V0 Multi target holder (setup width 380cm, for use with bullet trap)

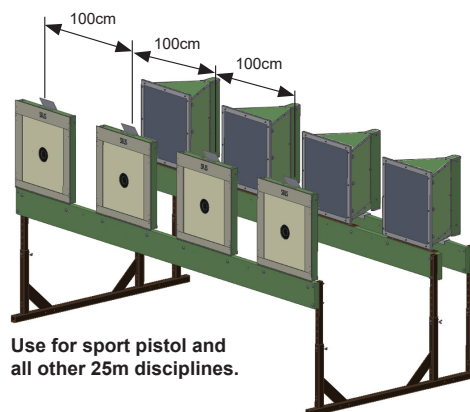
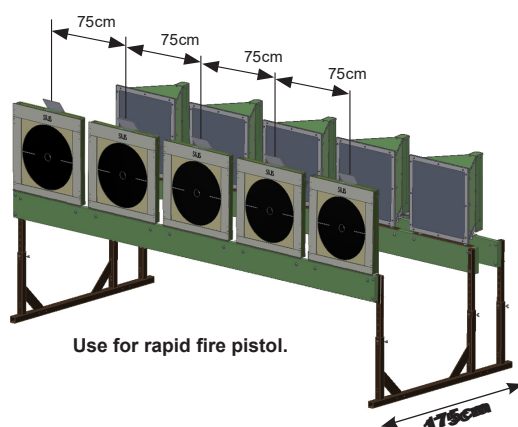

Only 4 lanes can be used with the short holder SHS06V0.

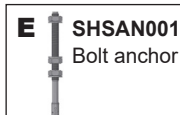

Pos.	Article no.	Description
Multi target holder for LS25/50		
1	SHS04V0	Multi target holder, setup width 380 cm, for use without bullet trap, excl. feet, wheel casters and floor fixings. For rapid fire pistol, sport pistol and CISM.
2	SHS06V0	Multi target holder, setup width 380 cm, for use with bullet trap, excl. feet, wheel casters and floor fixings. For rapid fire pistol, sport pistol and CISM.

Multi target holder long for 25m ISSF disciplines

The target holders SHS04V1 (without holder for bullet trap) resp. SHS06V1 (with holder for bullet trap) are suitable for rapid fire pistol as well as for all other 25m pistol disciplines. In contrast to the multi target holder SHS04V0 resp. SHS06V0, five targets can be mounted on this holder for every respective ISSF discipline. For this reason we recommend using the multi target holder SHS04V1 wherever possible.

1 SHS04V1 Multi target holder (setup width 468cm, for use without bullet trap)

Use for rapid fire pistol.

Use for sport pistol and all other 25m disciplines.

E SHSAN001 Bolt anchor

A SHS04AN001 Tilt foot

B1 SHS04AN002 Wheel caster Ø 200mm, incl. 2 cross struts

C SHS04AN005 Floor fixing temporarily

D SHS04AN006 Floor fixing permanently

2 SHS06V1 Multi target holder (setup width 468cm, for use with bullet trap)

Use for rapid fire pistol.

Use for sport pistol and all other 25m disciplines.

E SHSAN001 Bolt anchor

A SHS04AN001 Tilt foot

B2 SHS06AN001 Wheel caster Ø 200mm, incl. 4 cross struts

C SHS04AN005 Floor fixing temporarily

D SHS04AN006 Floor fixing permanently

Pos.	Article no.	Description
Multi target holder for LS25/50		
1	SHS04V1	Multi target holder, setup width 465 cm, for use without bullet trap, excl. feet, wheel casters and floor fixings. For rapid fire pistol, sport pistol and CISM.
2	SHS06V1	Multi target holder, setup width 465 cm, for use without bullet trap, excl. feet, wheel casters and floor fixings. For rapid fire pistol, sport pistol and CISM.
Optional accessory and spare parts		
A	SHS04AN001	Tilt foot for multi target holder, set with 4 pieces
B1	SHS04AN002	Wheel caster for multi target holder, Ø 200mm, set with 4 pieces, incl. 2 cross struts
B2	SHS06AN001	Wheel caster for multi target holder, Ø 200mm, set with 4 pieces, incl. 4 cross struts
C	SHS04AN005	Floor fixing temporarily, for target holder, set with 2 pieces
D	SHS04AN006	Floor fixing permanently, for target holder, set with 2 pieces
E	SHSAN001	Bolt anchor with washer and nuts, set with 4 pieces

Light signal for LS25/50

The target LS25/50 is equipped with a red/green light signal, as used for 25m disciplines. Just the display mirror (non-splintering material) must be mounted.

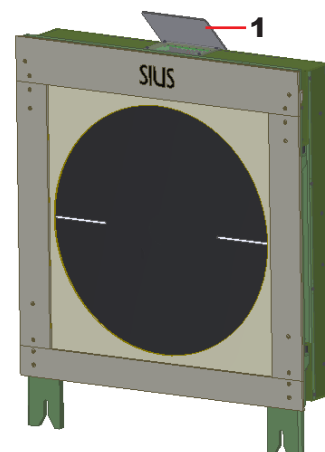

Pos.	Article no.	Description
	Light signal for LS25/50	
1	LS2550AN002	Display mirror, Dibond 3mm



Bullet trap for small bore projectiles

A special bullet trap has been developed for small bore weapons (for calibers 22, 32, 38, except steel shell projectiles). This allows bullets to be caught in a simple manner.

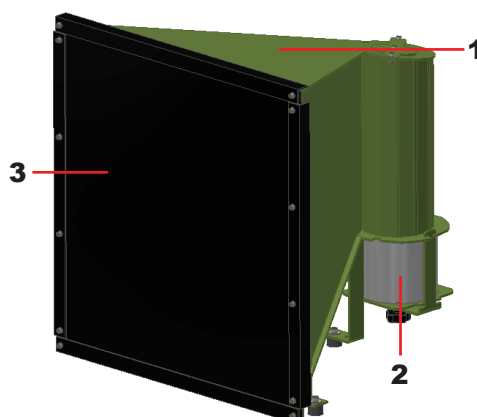

Pos.	Article no.	Description
Bullet trap for target LS25/50		
1	KFS2550	Bullet trap for target LS25/50
Optional accessory and spare parts		
2	KFS2550A025	Bullet bucket Ø 160/154 x 130 mm, polycarbonat
3	KFS2550A012	Rubber membrane (sound absorber), size (WxHxD): 675x660x8mm

Phantom targets for ISSF competitions

Phantom targets are mounted in front of the bullet traps. The backing targets of the ISSF can be mounted onto them. They are used to detect cross shots.

An optional center shade provider is available, which prevents incidence of light in the centre behind the target. This ensures, that even a heavily shot-up target centre remains visible as black for the shooter.

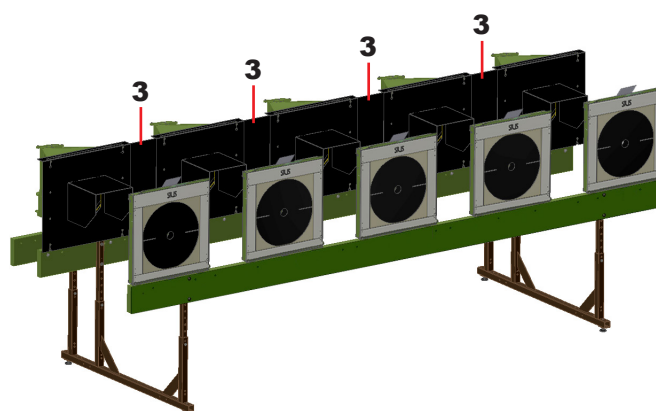
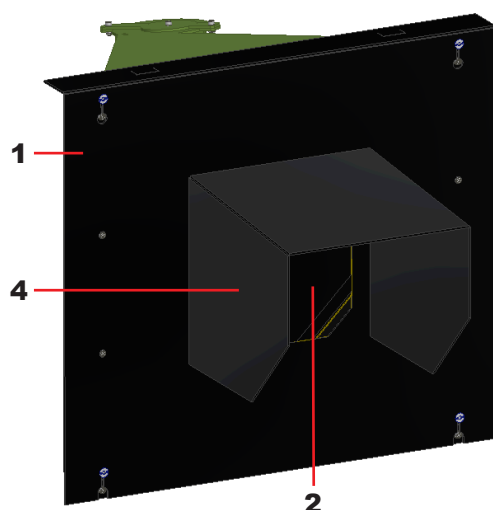

If mounted on a multi target holder (1m distance target to target), the separate phantom targets can be merged by using connection parts.

Pos.	Article no.	Description
Phantom targets for ISSF competitions		
1	PTM2550A005	Phantom target for manual shot control and cross shot detection, PP-multi-wall, size (WxHxD): 770x690x3,5mm
2	AZF046/100	Witness paper for replacement (option), for manual shot control, set of 100 pieces
3	PTM2550A006	Connection part for phantom targets PTM2550A005, PP-multi-wall, size (WxHxD): 400x685x3,5mm (needed if distance target to target is 1m)
4	PTM2550A007	Center shade provider for phantom target (option), PP-multi-wall, size(WxHxD): 327x316x350mm

Reinforced front frame for large calibre ammunition for LS25/50

A reinforced front frame is necessary for the protection of the LS25/50 when using solid jacketed bullets up to a maximum of 1500 Joules. The reinforced front frame is composed of a steel frame for main protection and a supplementary plywood panel that serves as protection from ricochets.

The reinforced front frame is used instead of the aluminum frame.

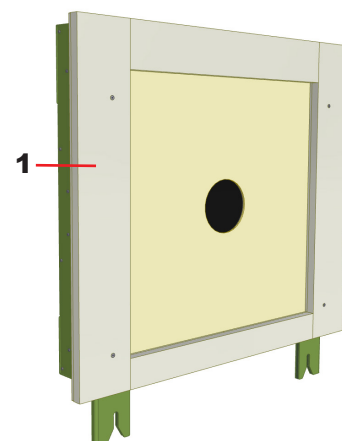

Pos.	Article no.	Description
Reinforced front frame for large calibre ammunition for LS25/50		
1	LS2550AN001	Reinforced front frame for large calibre ammunition for LS25/50 (reinforced front frame large calibre with plywood panel, spacer disc/washer)
Spare parts		
	LS2550AN007	Reinforced front frame for big bore ammunition
	LS2550D004	Ply wood front frame panel for LS25/50, 19mm thick

SIUS AG

Im Langhag 1 | CH-8307 Effretikon | Switzerland

Phone +41 52 354 60 60

www.sius.com | info@sius.com